

# PERFORMANCE MONITOR USE



## IMPORTANT NOTE:

For complete warranty details, additional information about Concept2 or to register to receive important product updates, please visit:

[concept2.com/registration](http://concept2.com/registration)

[concept2.com](http://concept2.com)

# OVERVIEW OF THE PERFORMANCE MONITOR(PM)

For more detailed information about using the Performance Monitor, please visit [concept2.com/pm](http://concept2.com/pm).

## CHANGE UNITS

allows you to select meters, pace, watts or calories. Push this button any time while setting up a workout, rowing or viewing results.

## CHANGE DISPLAY

allows you to choose another display. Push this button any time while rowing. Each time you press [CHANGE DISPLAY] a new display is shown. See below.

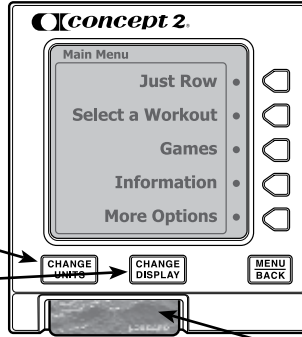

These buttons allow you to:

- make menu selections
- increment numbers for setting workouts and date/time
- view alternate displays while rowing

## MENU BACK

turns on the monitor and displays **Main Menu** or the previous menu. After a workout, press this button to end the workout and return to the **Main Menu**.

**LogCard:** when a LogCard is present, workout data will be stored on the LogCard. After your workout, return to the **Main Menu** before removing the LogCard to ensure proper storage of data. (If no LogCard present, data is stored in **Memory**.) Use the "Concept2 LogCard Utility" to back up your LogCard data to your PC. (USB cable provided)

**Note:** A LogCard is provided with every Performance Monitor (PM). Each card can be shared by up to five users. Additional cards can be purchased from Concept2.

## Five Graphic Displays



Note: Heart Rate (HR) will be displayed only if HR Interface is in use.

# GETTING STARTED

## Turning the PM On/Off:

The PM will turn on when you:

- take a stroke
- press [MENU/BACK]
- insert a LogCard or USB cable
- insert batteries or battery pack

The PM turns off after four minutes of inactivity on a workout screen, or after one minute on the **Main Menu** screen.

## Setting Date and Time:

The first time you turn on the PM, you are prompted to set the date and time. This ensures your results are associated with the proper date.

- If you ever need to re-set Date/Time, from **Main Menu** press **More Options > Utilities > Set Date and Time**. Use buttons as indicated to increase or decrease time.

## General Operation:

- The PM automatically displays your workout data as soon as you start rowing. It is not necessary to press any buttons if you do not want to.
- Press [MENU/BACK] to go back to the previous display.
- Press [CHANGE UNITS] or [CHANGE DISPLAY] at any time during and after your row to view different units and a different presentation of your workout data.
- We encourage you to explore the menu and experiment with the buttons!

## Using a Heart Rate Monitor:

The PM displays your heart rate if one of the following heart rate systems is in use:

	PM3	PM4
	The PM3 will receive heart rate transmission from a Polar™ chest belt IF the optional Concept2 Heart Rate Receiver (available from Concept2) is in use and plugged into the PM3.	The PM4 will receive heart rate transmission from a Polar™ chest belt IF the optional Concept2 Heart Rate Receiver (available from Concept2) is in use and plugged into the PM4.
	Not available.	The PM4 will receive heart rate transmission directly from a Suunto™, Garmin® or ANT+HR™ chest belt. See <b>More Options</b> for set up.

# UNDERSTANDING THE PM MENU OF OPTIONS

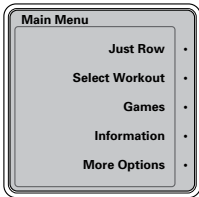

## Just Row – Automatic Operation

**Just Row** is designed for those days when you would rather not push any buttons or pre-set your workout. Your first stroke will turn on the PM and start recording your workout time and distance automatically. You may also select **Just Row** to set up the PM screen before you start rowing.

**Note:** You must row for at least one minute for results to be saved in memory or on your LogCard. **Just Row** allows you to row up to 50,000 meters.



## Select Workout

The PM lets you choose or create a wide variety of workouts. You can choose from the **Standard List** of pre-set workouts provided on the PM, or you can create workouts of your own and build your own **Custom List**. If you have a LogCard, you can store your five favorite workouts (**Favorites**) on the LogCard. The **Re-Row** function allows you to “re-row” a saved workout (in **Memory** or on the LogCard) by rowing against a Paceboat driven by a split-by-split\* replay of the saved workout. You can also race a Paceboat in a **New Workout** by entering a pace for the Optional PaceBoat setting when you set up the workout.

\*Understanding Splits: Your workout results will be displayed and stored in two ways: as a final result for the total distance or time, and as a set of points along the way called splits. The splits show how your pace varied through the workout. If you select a workout from **Standard List**, **Custom List**, or **Favorites**, the duration of the split will be set for you. If you set up a **New Workout** you have the opportunity to set the split duration. The PM divides your New Workout into five segments, or splits, unless you alter the split duration during set up. Interval workouts are not formatted to utilize splits.

To edit **Custom List** you must have a LogCard inserted. From **Main Menu** select **More Options > LogCard > LogCard Utilities > Edit Custom List**. This enables you to copy workouts from **Favorites** on your LogCard to the **Custom List** on the monitor.

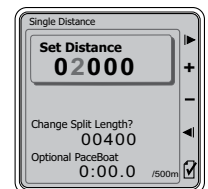
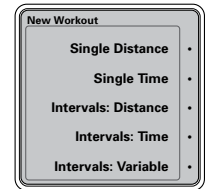

## Games



**Fish Game:** Earn points by catching good fish, and avoid losing points by getting caught by the bad fish! Row harder and your fish swims up. Row easier and your fish swims down. Each game lasts four minutes. Your Fish Game workout information (time, distance, pace per 500 meters, etc.) is logged to your LogCard (or PM **Memory** if rowing without a LogCard) just like a regular workout.

**Darts (PM4 Only):** This game rewards consistency in stroke rate and power output. You get 300 darts to “throw” in a game and your score is calculated just like a real game of darts. A bull’s eye is worth 50 points and the next three rings are worth 25, 10 and 5 points each.

**Target Training (PM4 Only):** This game rewards consistency and gives you additional options to make it a more powerful training tool. Your score is the percent of the best possible score obtainable. A bull’s eye is worth 5 points, and the remaining rings are worth 3, 2, and 1 point.

Target Training offers two choices:

- **Just Row** – An open-ended target training session that allows you to row for as long as you like. Like the Darts game, the target pace will be based on your recent strokes.
- **Advanced** – Gives maximum control of your target training session by allowing you to set your target pace, target stroke rate and workout time. If you are interested in achieving a target pace and stroke rate, and holding it for a pre-determined length of time, this is the game for you.

**Racing (PM4 Only):** The PM4 enables you to set up races with up to eight PM4-equipped indoor rowers without using a computer. This can be done wirelessly or by using Ethernet patch cables available from Concept2. If using cables, be sure to plug them in before starting the race.

One person creates the race on their PM4 by following the PM4 menu; others join in using their own PM4. The race creator is always in Lane 1 and starts the race when all are ready. Remaining lane numbers are assigned based on order of entry into the race. The race screen displays names for racers using LogCards.

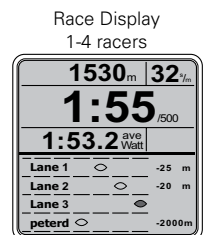
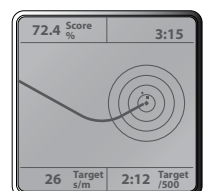
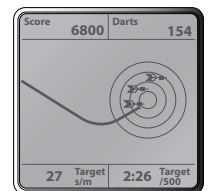
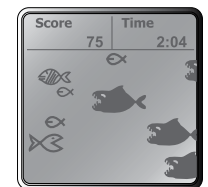

If using Suunto™ chest belts, you must use cables to race. In certain environments where other devices (WiFi, Bluetooth, etc.) are in use, Concept2 suggests use of cables. Only one wireless race can be in progress at a time.

**Biathlon:** This game simulates the Olympic sport of Biathlon. Ski (or row) intervals that alternate with target shooting or another activity. Choose from a range of penalty distances. The PM keeps track of your “range” time and your total elapsed time.

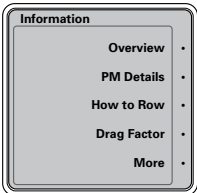
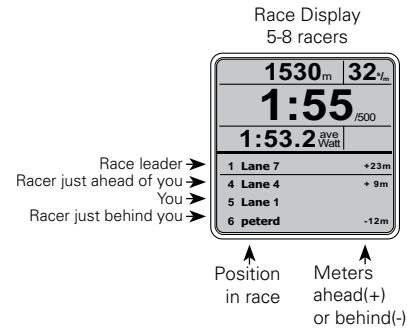

## Information/Help

The PM contains on-board information to help you if the manual is not available. This section includes a brief rowing lesson with an animation of proper rowing technique, an explanation of the **Drag Factor**, information about batteries and more. We encourage you to press the **Information** button from the **Main Menu** and read through the information provided.

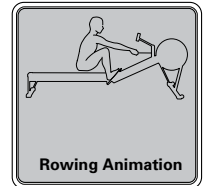

## More Options

The **More Options** menu provides the following functions and utilities:

- **Display Drag Factor:** Drag factor is a measure of fan load. The PM self-calibrates by recalculating the drag factor every stroke so you get a true measure of your effort regardless of the damper setting or changing conditions.
- **Utilities:** Allows you to re-set the date, time or language. You can also adjust the contrast of the LCD, check battery status and add workouts to the **Custom List**.
- **Connect Heart Rate:** (PM4 only) Suunto™, Garmin® or ANT+™ heart rate chest belts can be used to display and record your heart rate. Each chest belt has a unique ID number. Use this menu to select your chest belt's ID number. Save your ID number to a LogCard to have the LogCard automatically recognize your chest belt (for future workouts).  
For more information, visit [concept2.com/hearttrate](http://concept2.com/hearttrate).
- **Memory/LogCard:** The PM stores workouts in two ways. If no LogCard is present, the PM will store your most recent workouts in **Memory**. The oldest are automatically deleted. If a LogCard is inserted before a workout, the workout data is stored on the LogCard, which stores approximately 300 workouts. The LogCard enables you to track your total and monthly meters and your performance during each split or interval of your workout (including heart rate, if available). You can view your workouts listed by date or by type. Workout data can be moved from **Memory** to LogCard.
- **Link:** (PM4 only) Wirelessly connect to Garmin watches that display the **LINK HERE** logo, ANT+ enabled smartphones and Concept2 mobile applications.

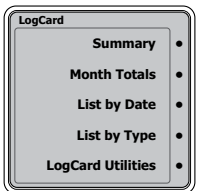
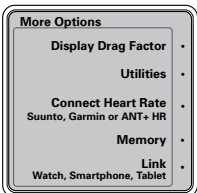

Monthly Totals	Judy
Dec	7:44:40 88260
Nov	3:04:10 34880
Oct	7:37:50 89000
Sep	8:40:50 100950
Aug	47:10 9050
July	:00 0
Jun	1:44:50 21050
May	5:59:10 72160
Apr	9:09:30 109390
Mar	8:32:10 99260
Feb	7:20 1500
Jan	1:55:10 21570

Additional information is available at [concept2.com](http://concept2.com) and [c2forum.com](http://c2forum.com).

## BATTERY INFORMATION

PM3	PM4
The PM3 uses two alkaline D-Cell (LR20) batteries. When you are rowing, the flywheel provides a portion of the power to extend battery life (Model D Indoor Rower only).	Comes equipped with rechargeable battery pack. Recharge rate depends on usage pattern of rower: the more and harder you row, the more quickly the PM4 charges. Under certain usage patterns, it may be better to use two alkaline D-Cell (LR20) batteries. May also be recharged by connecting PM4 to PC using USB cable. Refer to <a href="http://concept2.com/pm4">concept2.com/pm4</a> for more info.

**Notes:**

- 1) Remove batteries or battery pack from the PM3 or PM4 if monitor will not be used for a period of four months or more.

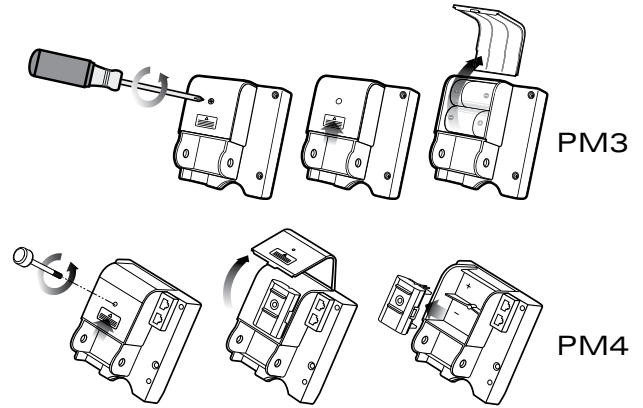

Battery compartment: Loosen screw and press thumbstrike in direction shown to open.

**Safety Information for PM4 Rechargeable Battery Pack**

Do not:	Do:
<ul style="list-style-type: none"> <li>• Open the plastic case</li> <li>• Drop the battery pack</li> <li>• Allow battery pack pins to touch each other or any metal object</li> <li>• Use if damaged or leaking</li> <li>• Trash, incinerate, crush, etc.</li> </ul>	<ul style="list-style-type: none"> <li>• Use only in a PM4; if not used in PM4, store carefully so pins are not shorted</li> <li>• Keep clean and dry</li> <li>• Use between 0° and 40° C</li> <li>• Charge (row or plug PM4 into USB) after prolonged period of non-use</li> <li>• Keep battery pack away from children</li> <li>• Recycle properly</li> </ul>

WARNING: If batteries leak, do not use them. Battery fluids are corrosive and can damage eyes, irritate skin, etc. If contact occurs, wash affected area immediately and thoroughly with water.

**MISCELLANEOUS**

● **Cleaning the PM**

Use a cloth lightly dampened with water only. Do not spray with a cleaner or leave in the rain.

● **Formulas Used**

Watts = 2.80/(sec/meter)^3

Calories/Hour = Kcal/hr = (watts) x (4) x (0.8604) + 300

● **Bottom View of PM**

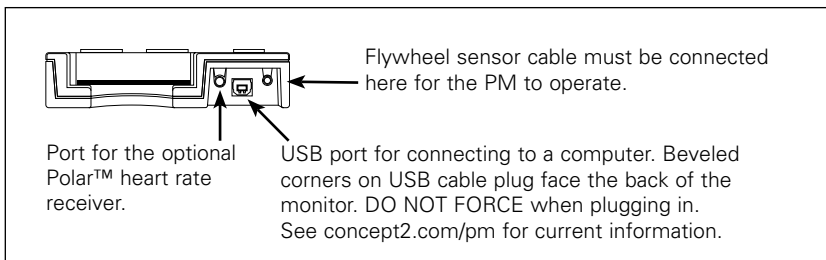

● **Back View of PM**

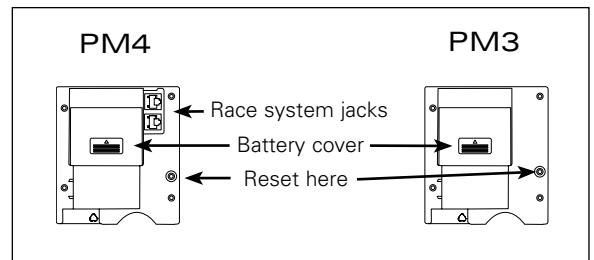

**TROUBLESHOOTING**

1. If the PM malfunctions or does not "wake up," reset PM:
  - Insert a pen/pencil tip into the reset hole on the back and press lightly.
  - Remove the batteries for 30 minutes and insert two new alkaline D-Cell (LR20) batteries.
2. To change language: press [MENU/BACK] until screen stops changing. Press fifth grey button on right, then press second grey button on right twice, and select your language. Alternately, hold down CHANGE UNITS and CHANGE DISPLAY and reset monitor. You can then select your desired language. (Note: This procedure will reset PM to factory settings.)
3. If your computer does not recognize that your PM3/PM4 is connected to it try one of the following:
  - Use another computer and/or USB cable.
  - Remove batteries and USB cable for 30 minutes then reinsert batteries and try again.

Refer to [concept2.com/pm](http://concept2.com/pm) for more information and software updates.